

# ASSEMBLY MANUAL

## CHC25, CHC30

### Combine Header Carrier



#### **HORST WAGONS**

8082 Rd 129

Listowel, ON N4W 3G9

Canada

519-291-4162

1-866-567-4162

Fax 1-519-291-5388

[sales@horstwelding.com](mailto:sales@horstwelding.com)

[www.horstwelding.com](http://www.horstwelding.com)

## **TABLE OF CONTENTS**

CHC25, CHC30 Included Parts-----	2
Step by Step Assembly Instructions-----	3 - 4
Light Bracket Installation-----	5

# CHC25 & CHC30 Included Parts

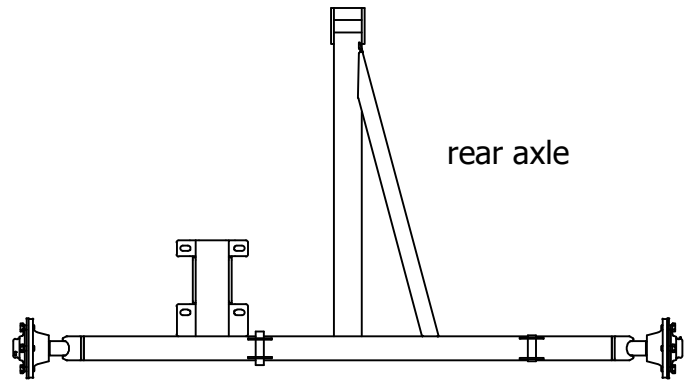
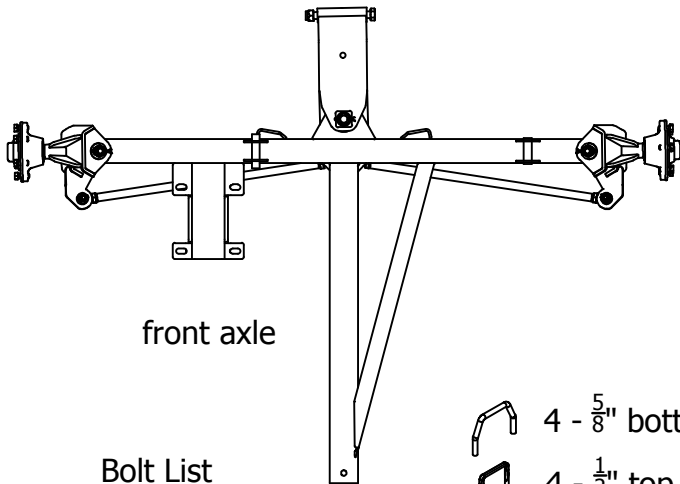

## Bolt List

- 4 -  $\frac{5}{8}$ " x 6" bolts
- 2 -  $\frac{5}{8}$ " x 4  $\frac{1}{2}$ " bolts
- 8 -  $\frac{5}{8}$ " x 1  $\frac{1}{2}$ " carriage bolts
- 4 -  $\frac{1}{2}$ " x 1  $\frac{1}{2}$ " bolts
- 6 -  $\frac{3}{8}$ " x 1  $\frac{1}{2}$ " bolts
- 22 -  $\frac{5}{8}$ " locknuts
- 12 -  $\frac{1}{2}$ " locknuts
- 6 -  $\frac{3}{8}$ " locknuts
- 8 -  $\frac{5}{8}$ " flat washer
- 5 - #9 hitch pins

- 4 -  $\frac{5}{8}$ " bottom rail U-bolts
- 4 -  $\frac{1}{2}$ " top rail U-bolts
- 1 - reach retainer ring
- 4 -  $\frac{5}{8}$ " x 7" drawpins
- 2 - top rail mount brackets
- 2 - vertical adjuster brackets

- 2 - adjustable shoe assemblies
- 2 - standard header shoes

- 4 -  $\frac{3}{4}$ " x 11" pins
- 2 - strap ratchets
- 2 - 2" x 52" nylon straps

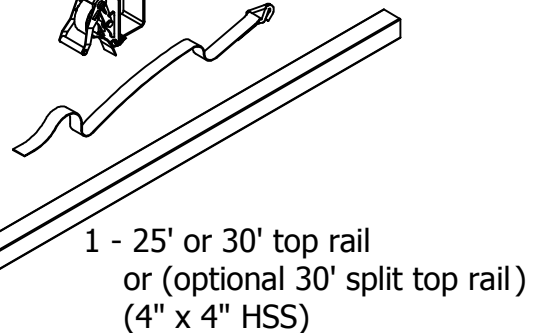
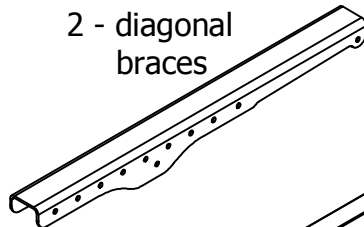

- Additional components for "30ft. split top rail" option

  - 6 -  $\frac{1}{2}$ " top rail U-bolts
  - 12 -  $\frac{1}{2}$ " locknuts

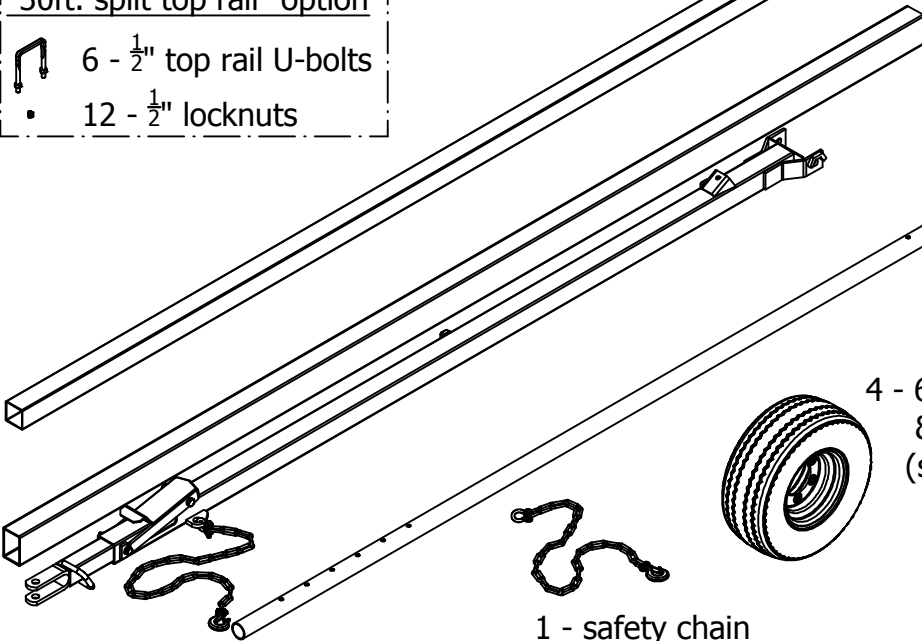

- 4 - 6 bolt rims & tires (size varies)

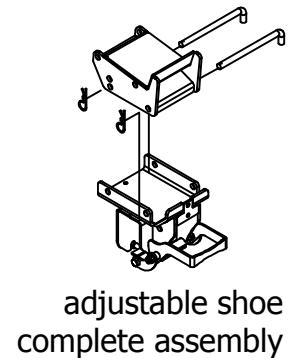

# Model **CHC25, CHC30**

## Step by Step Assembly Instructions

### **STEP 1 :**

- A. Install wheels. (Torque to 180 Lbs.-ft.)
- B. Bolt reach tube between front & rear axles.

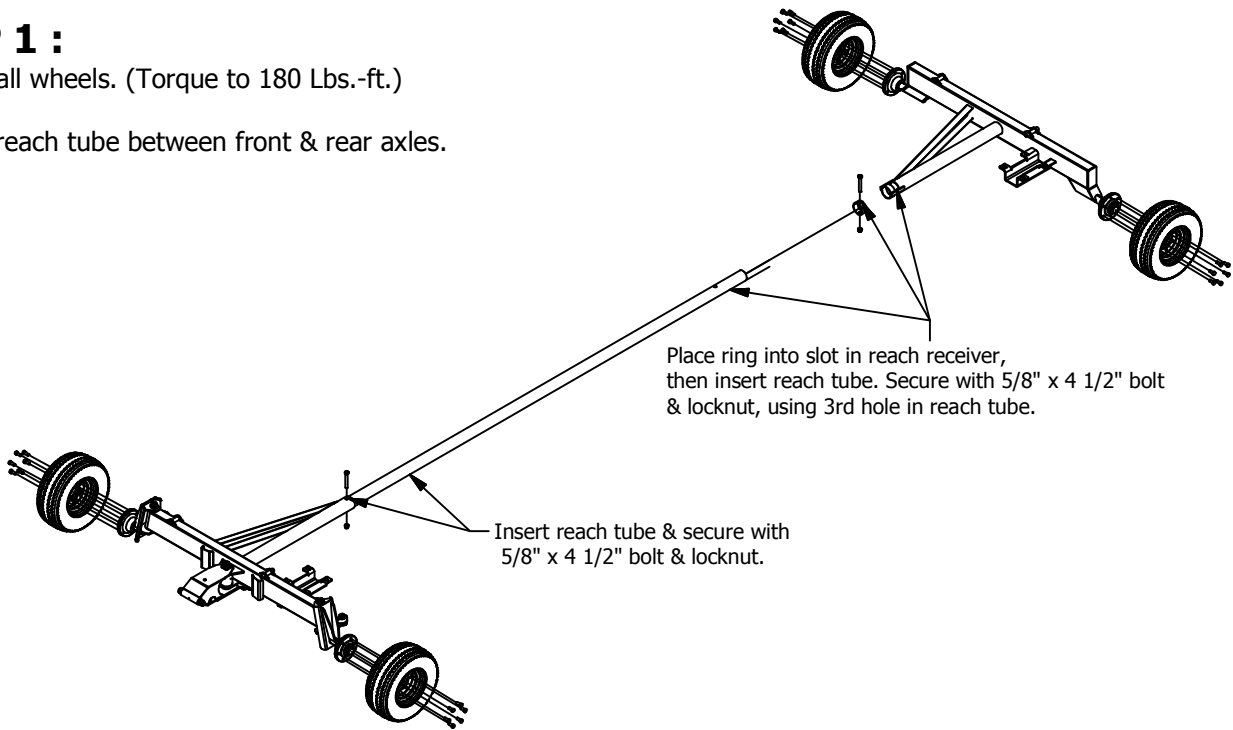

### **STEP 2 :**

- A. Drop 4 x 6 x 213 tube into cradle brackets on both axles. Center it between front and back and secure with 5/8" U-bolts.
- B. Mount Tongue assembly using 1 1/8" x 10 3/8" bolt in tongue bracket. Install safety chain provided.

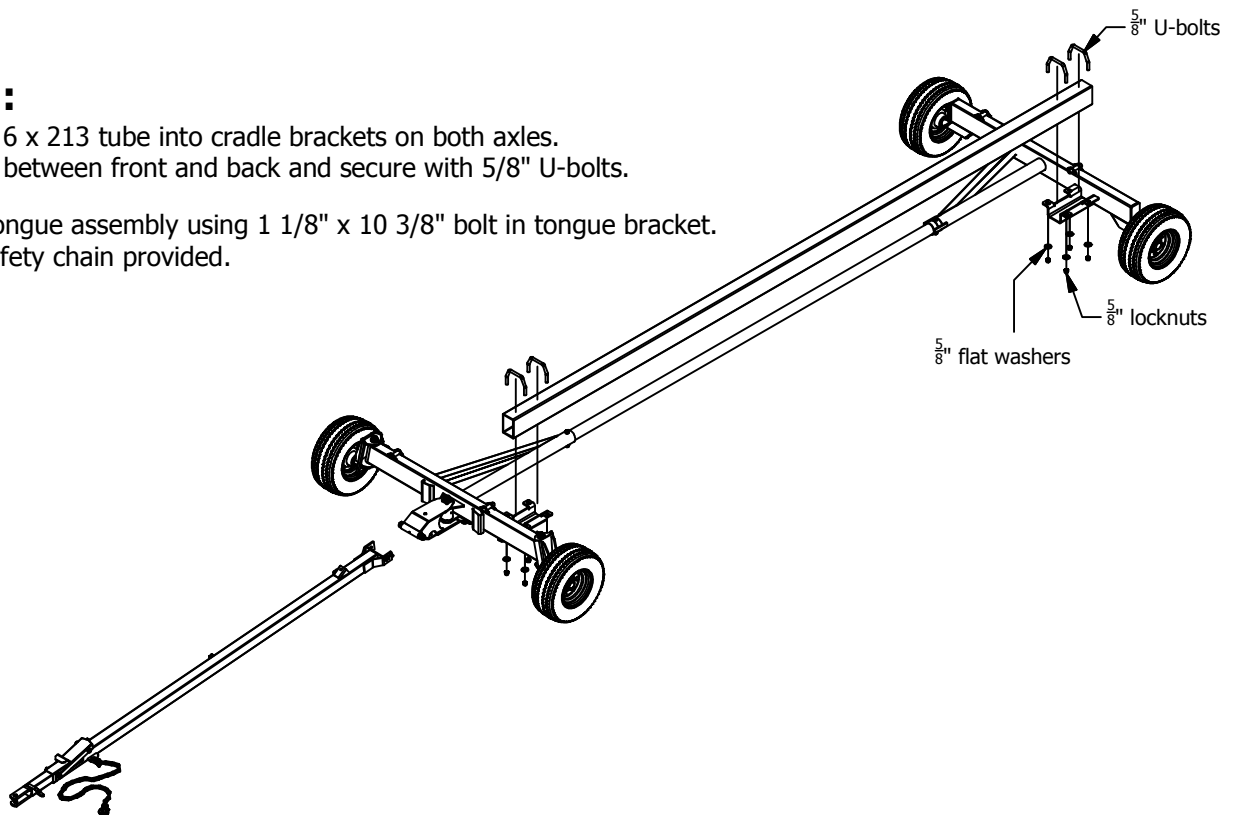

### STEP 3 :

- A. Pin vertical adjuster bracket to right bushing on top of axle using 5/8" drawpin (single hole toward top).
- B. Secure diagonal channel to left bushing on top of axle, and top hole on vertical adjuster bracket, using 5/8" x 6" bolts and locknuts.
- C. Pin top rail bracket to top of diagonal channel at desired setting, using 5/8" drawpin.

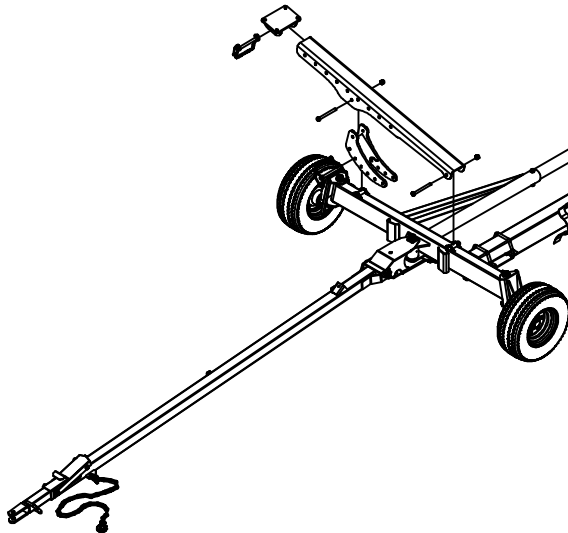
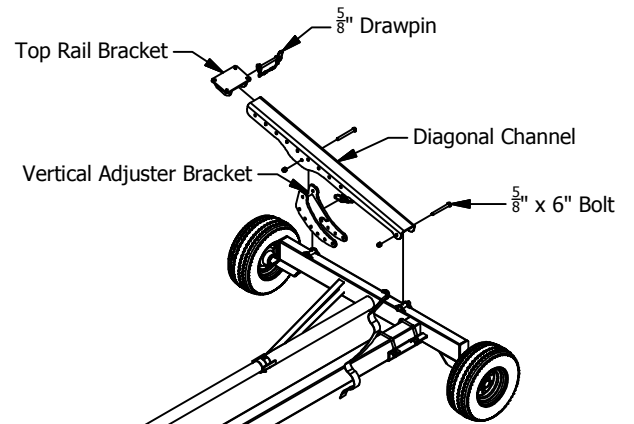

### STEP 4 :

- A. Set 4" x 4" top rail on top rail brackets and start 1/2" U-bolts & locknuts. Before tightening, top rail must be centered from front to back.
- B. Mount adjustable shoes and strap ratchet assemblies on bottom rail tube (see shoe diagram on pg. 5 for detailed assembly instructions).

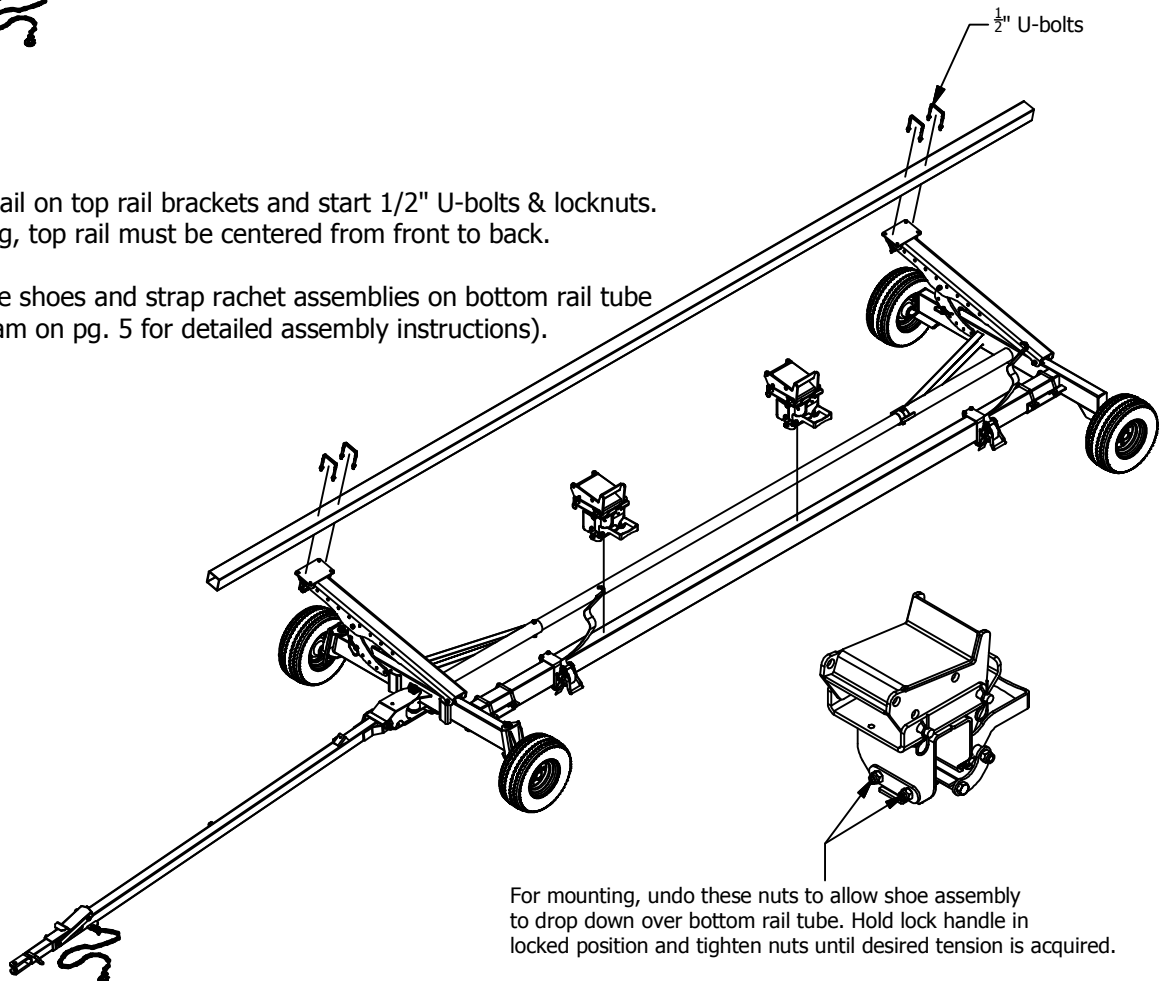

# Light Kit Installation (optional):

- A. Secure mounting brackets (illustrated below).
- B. Run wire lead forward on outside of reach tube and along side of tongue, through loop. Secure exposed wire using wire clamps provided. Use nylon straps at front of tongue. (Wire length does not need to be altered)

Wagon not exactly as pictured.

